



www.rebar-machines.com

Rebar cutting machines Cesoie meccaniche



Made in
Italy



Rebar machines for cutting reinforcement steel bars. Highly performant and reliable products, they are easy to use and with easy maintenance. Manufactured with all components "Made in Italy". Cast iron frame on the "E" models.

Macchine per il taglio del tondo da cemento armato, garantiscono alte prestazioni ed affidabilità, sono semplici da usare e hanno semplice manutenzione. Sono macchine con componenti "Made in Italy". Sulle macchine della nuova serie - con "E" finale - la struttura è in ghisa.

FS2050



FS2043



R.P.M. 1'



HP KW

65 kg/mm²



1 Ø 2 Ø 3 Ø

85 kg/mm²

1 Ø 2 Ø 3 Ø



l x p x h cm



kg



YEAR
ANNO

warranty
garanzia

	R.P.M. 1'	HP	KW	65 kg/mm ²			85 kg/mm ²			l x p x h cm	kg	YEAR ANNO	warranty garanzia
				1 Ø	2 Ø	3 Ø	1 Ø	2 Ø	3 Ø				
FS2036	90	4	3	30	20	16	26	18	14	105x61x82	424	3	1
FS2040	90	4	3	34	26	20	30	20	16	118x71x87	589	4	1
FS2050	40	5,5	4	44	30	24	36	26	22	130x71x92	712	4	1
FS2055	40	7,5	5,5	46	32	26	40	30	22	130x71x95	718	4	1
FS2033E*	46	3	2,2	28	20	16	26	18	14	82x50x68	234	1,5	2
FS2037E	52	4	3	30	22	18	28	20	16	85x55x72	242	1,5	2
FS2043E	40	4	3	34	28	22	32	22	18	98x56x77	397	2	2
FS2053E	37	5,5	4	46	32	24	40	30	22	117x65x87	627	3	2
FS2057E	37	7,5	5,5	48	34	26	42	32	24	117x65x92	638	3	2
FS2077E	30	10	7,5	64	44	36	54	36	30	152x85x110	1300	8	2

* single-phase or three-phase/ monofase o trifase

Equipment/ Dotazione

FS2036/ FS2040/
FS2050/ FS2055

FS2033E/ FS2037E/
FS2043E/ FS2053E/
FS2057E/ FS2077E

✓ Including/
In dotazione
+ Optional/
Opzionale

Cutting blades with 4 cutting
edges

Lame con 4 spigoli di taglio



A set of allen keys

Set di chiavi a brugola



A set of wheels for the
machine handling

Set ruote movimentazione
macchina



A bar sliding device

Rullo scorri barra



Magneto-thermal switch for
overload motor protection

Interruttore generale con
protezione magnetotermica



Steel base with remote foot
pedal

Basamento con pedaliera



1

Lubrication pump

Pompa di lubrificazione



2

Screw locator

Riscontro a vite



3

Five pin three-phase plug

Spina a 5 Poli

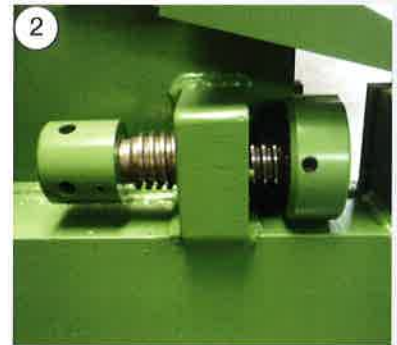

Rebar bending machines Piegatrici meccaniche



Made in
Italy



Rebar machines for bending reinforcement steel bars, designed in order to deal with important production volumes, in total safety and ease of use.

Maintenance is simple and the highest quality components Made in Italy ensure long life and durability.

The new models "E" have a bigger diameter bending plate and a bigger set of bushes

Macchine piegaferro per la piegatura del tondo da cemento armato, progettate in modo da poter affrontare volumi di produzione importanti, in totale sicurezza e praticità di utilizzo. La manutenzione è semplice e i componenti "Made in Italy" di primissima qualità ne garantiscono la lunga durata e la resistenza. Le macchine della nuova serie "E" sono dotate di un piatto di piegatura di maggior diametro e di bussole più grandi.

FS1784



with long saddles for double bending (optional)

FS4037E



R.P.M. 1'



HP KW

65 kg/mm²



85 kg/mm²

1 Ø 2 Ø 3 Ø 1 Ø 2 Ø 3 Ø



l x p x h cm



kg



kg



YEAR ANNO
warranty
garanzia

	R.P.M. 1'	HP	KW	65 kg/mm ²			85 kg/mm ²			l x p x h cm	kg	YEAR ANNO	warranty garanzia
				1 Ø	2 Ø	3 Ø	1 Ø	2 Ø	3 Ø				
FS1782	9	4	3	32	24	18	30	22	18	93X90X85	345	8	1
FS1784	6	4	3	36	28	22	34	26	20	110x95x89	474	13	1
FS1785	6	5,5	4	42	32	26	38	30	24	110x95x89	553	13	1
FS1785b	5,5	7,5	5,5	46	36	30	42	34	26	110x95x89	596	13	1
FS4033E*	11	3	2,2	30	22	18	28	20	16	83x80x85	299	5	2
FS4037E	9	4	3	34	26	20	32	24	18	94x90x85	352	8	2
FS4043E	6	4	3	38	30	24	36	28	22	113x95x89	486	13	2
FS4053E	6	5,5	4	44	34	28	40	32	24	113x95x89	580	13	2
FS4057E	5	7,5	5,5	46	36	30	42	34	26	113x95x89	682	13	2
FS4087E	5	10	7,5	60	42	34	50	36	30	160x115x95	1635	25	2

* single-phase or three-phase/ monofase o trifase

Equipment/ Dotazione

FS1782/ FS1784/ FS1785/ FS1785b
 FS4033E/ FS4037E/
 FS4043E/ FS4053E/
 FS4057E FS4087E

✓ Including/
 In dotazione
 + Optional/
 Opzionale

A checking block for rebar positioning on working table

Riscontro per fissaggio barra sul piano di lavoro



A square pivot to be used with the checking block

Perno quadro da utilizzare con riscontro



A stirrup bending pivot used to obtain small curving radii

Perno piegastaffe per raggi di curvatura stretti



3 bush holding pivots in special steel and 1 set of bushes

3 perni portabussola in acciaio speciale e 1 set di bussole



2 reversal pivots to determine the angle of bending

2 piolini per angolo di piegatura



A set of Allen keys

Set di chiavi a brugola



Remote foot pedal

Pedaliera elettrica



A set of wheels for the machine handling

Set di ruote per movimentazione macchina



2 emergency push button

2 pulsanti di emergenza



Long saddles for double bending

Carrelli lunghi per realizzare la doppia piegatura



* FS1782 including 2 short saddles, long saddles are optional. / FS1782 include 2 carrelli corti, i carrelli lunghi sono optional.

Rebar combined machines Macchine combinate



Made in
Italy



Rebar combined machines for cutting and bending concrete reinforcement steel bars: one only product making both operations, a cheap and not bulky way to work on construction sites with a rather limited volume of work. All units have wide turning plate, as well as long saddles, for "double bending". The best available components "Made in Italy" ensure the durability of these machines.

FS1733

Macchine combinate taglia e piegaferro per il tondo da cemento armato: un unico prodotto che rende possibili entrambe le operazioni, un modo economico e poco ingombrante per lavorare in cantieri con volumi di lavoro modesti. Tutte le macchine hanno un ampio piatto girevole, così come i carrelli lunghi, per la "doppia piegatura". I migliori componenti "Made in Italy" delle migliori marche contribuiscono a garantire l'alta resistenza e la qualità del prodotto.



	R.P.M. 1'			65 kg/mm ²			85 kg/mm ²			l x p x h cm		kg	YEAR ANNO
	HP	KW	1 Ø	2 Ø	3 Ø	1 Ø	2 Ø	3 Ø				warranty garanzia	

FS1733*	10	3	2,2	24/28	18/20	14/16	22/26	16/18	14/12	80x100x83	346	6	2
FS1736	8	4	3	28/34	20/24	16/20	25/32	16/22	14/18	90x107x85	446	8	2
FS1746	6	4	3	32/38	22/28	18/22	30/36	20/24	16/20	105x120x90	629	14	2

* single-phase or three-phase/ monofase o trifase

EQUIPMENT/ DOTAZIONE

- ✓ Two blades in hardened steel
- ✓ A checking block to direct the rod on the working top
- ✓ A square pin to be used with the checking block
- ✓ A stirrup bending pin used to obtain small curving radii
- ✓ 3 bush holding pins in special steel and 1 set of bushes
- ✓ 2 reversal pins to determine the angle of bending

- ✓ Due lame in acciaio speciale
- ✓ Riscontro per fissaggio barra sul piano di lavoro
- ✓ Perno quadro da utilizzare con riscontro
- ✓ Perno piegastaffe per raggi di curvatura stretti
- ✓ 3 perni portabussola in acciaio speciale e 1 set di bussole
- ✓ 2 piolini per angolo di curvatura

- ✓ A set of Allen keys
- ✓ Remote foot pedal
- ✓ A set of wheels, for the machine handling
- ✓ 2 emergency push button switches to immediately stop the machine in case of emergency
- ✓ Long saddles to realize the double bending

- ✓ Set di chiavi a brugola
- ✓ Pedaliera elettrica
- ✓ Set di ruote per movimentazione macchina
- ✓ 2 pulsanti a fungo per arresto in caso di emergenza
- ✓ Carrelli lunghi per realizzare la doppia piegatura



Stirrup bending machines Macchine staffatrici



Made in
Italy



These stirrup benders are studied to produce reinforced concrete bars and to bend small diameters bars (Ø 16 mm max). 2 models available: the basic model FS1716, available both single phase and three phase, and the top version FS1718, three phase only. Standard equipment for the FS1716 is the stirrup linear measures. Instead for the FS1718, there is also included the stirrup bending vise and the advanced computerized angle control panel.

Queste staffatrici sono la soluzione ideale per la produzione di staffe da cemento armato e per lavorare barre di piccoli diametri (max. Ø 16 mm). 2 modelli disponibili: la versione base FS1716, disponibile sia in versione monofase sia trifase, sia la versione top FS1718, solo in versione trifase. La dotazione standard del modello FS1716 include il misuratore staffe. Nel caso della FS1718 sono inclusi inoltre: la morsa piega-staffe e, soprattutto, l'evoluto sistema computerizzato di controllo angoli piegatura.



FS1718



Angle type and different bends/
Tipi di angoli e di piegature

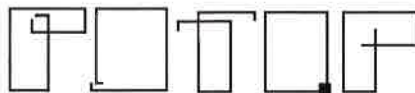

	R.P.M. 1'	HP	KW	65 kg/mm ²			kg	YEAR ANNO warranty garanzia
	1 Ø	2 Ø	3 Ø	4 Ø	7 Ø	10 Ø	l x p x h cm	

FS1716*	21	2	1,5	16	12	10	8	6	4	80x70x96	170	1
FS1718	18	2	1,5	16	12	10	8	6	4	92x90x85	280	1

* single-phase or three-phase/ monofase o trifase

EQUIPMENT/ DOTAZIONE

FS1716

- ✓ A checking block to direct the rod on the working top
- ✓ A square pivot to be used with the checking block
- ✓ A stirrup bending pin used to obtain small curving radii
- ✓ 2 Stirrups bending pivots Ø16mm and Ø32mm
- ✓ 3 bush holding pivot in special steel and 1 set of bushes
- ✓ 2 reversal pins to determine the angle of bending
- ✓ *Riscontro per fissaggio barra sul piano di lavoro*
- ✓ *Perno quadro da utilizzare con riscontro*
- ✓ *Perno piegastaffe per raggi di curvatura stretti*
- ✓ 2 perni piegastaffe temprati Ø16mm e Ø32mm
- ✓ 3 perni portabussola in acciaio speciale e 1 set di bussole
- ✓ 2 piolini per angolo di curvatura

- ✓ A set of Allen keys
- ✓ A remote foot pedal
- ✓ 2 emergency push button switches to immediately stop the machine in case of emergency
- ✓ 1 stirrup linear measurer

- ✓ *Set di chiavi a brugola*
- ✓ *Pedaliera elettrica*
- ✓ *2 pulsanti a fungo per arresto della macchina in caso di emergenza*
- ✓ *1 misuratore staffe*

- ✓ 2 hardened bush holding pivot
- ✓ A remote foot pedal
- ✓ 2 bushes Ø50-60mm
- ✓ A set Allen keys
- ✓ A stirrup linear measurer
- ✓ 2 perni porta bussola temprati
- ✓ *Pedaliera elettrica*
- ✓ 2 bussole Ø50-60mm
- ✓ *Set chiavi a brugola*
- ✓ *Misuratore staffe*

- ✓ Stirrup bending vise
- ✓ Computer 20 angles selector
- ✓ A set of wheels
- ✓ 2 emergency push button switches to immediately stop the machine in case of emergency

- ✓ *Morsa piega staffe*
- ✓ *Selettore a 20 angoli*
- ✓ *Un set di ruote*
- ✓ *2 pulsanti a fungo per arresto della macchina in caso di emergenza*

FS1718

OPTIONAL/ OPZIONALE

FS1716

- ✓ Stirrup bending tool
- ✓ *Attrezzatura per la piegatura staffe*

Spiral machines Calandre



Made in
Italy



The spiral bending machines responds to the specific requirement of obtaining circles, spirals and centering from large diameter bars. FS1777 is a special machine that allows to work on rods with diameters from 6 mm to 32 mm. The two-speed engine allows both the small diameters to bend rapidly and the larger diameter, tank to the power at a low speed. It allows you to make circles with unlimited bending radius and spirals with adjustable diameter from a minimum of 15 cm to a maximum of over 200 cm. Even the pitch of each spiral is totally adjustable.

FS1777



La calandra per ferro risponde all'esigenza specifica di ricavare cerchi, spirali e centine da barre di grosso diametro. FS1777 è una macchina speciale che consente di calandrare tondini con diametro dai 6 mm fino ai 32mm. Il motore a due velocità permette di piegare rapidamente i piccoli diametri e con potenza quelli più grandi. Permette di eseguire cerchi con raggio di curvatura illimitato (ferri per centine) e spirali con diametro regolabile da un minimo di 15 cm ad un massimo di oltre 200 cm. Anche il passo di ogni spirale è totalmente regolabile.



R.P.M. 1'



HP

KW



min. Ø

max. Ø



l x p x h cm



kg



kg



YEAR
ANNO
warranty
garanzia

FS1777

11/22

5/6

3,7/4,5

6

32

95x90x96

322

13

1

EQUIPMENT/ DOTAZIONE

- ✓ A set of Allen keys
- ✓ Double remote foot pedal, that allows to activate the towing rollers clockwise or counterclockwise

- ✓ Un set di chiavi a brugola
- ✓ Una doppia pedaliera elettrica per l'attivazione dei rulli di traino in senso orario ed antiorario

- ✓ A set of wheels for the machine handling
- ✓ 2 emergency push button switches to immediately stop the machine in case of emergency

- ✓ Un set di ruote per la movimentazione della macchina
- ✓ Due pulsanti a fungo, per arrestare la macchina in caso di emergenza



Benches with rollers m. 2/3/4
and beyond
*Banco per carico e scarico a rulli folli
m. 2/3/4 e oltre*

Computer 20 angles selector
Selettore a 20 angoli



6 angles selector
Selettore a 6 angoli





Spirals equipment
Attrezzatura per spirali

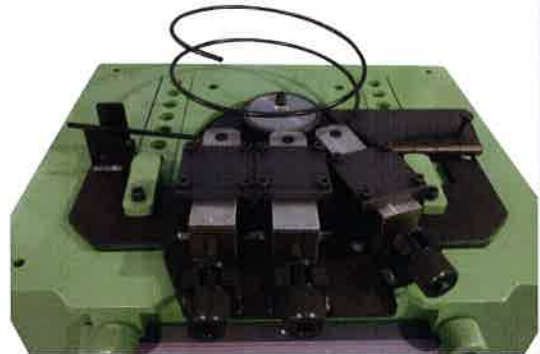
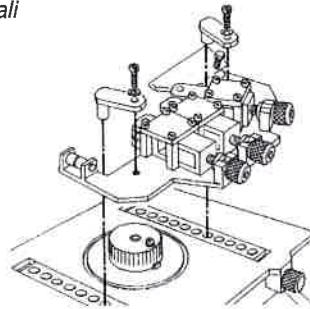

Stirrups measuring-bending
device
*Attrezzatura per la misurazione
e piegatura staffe*

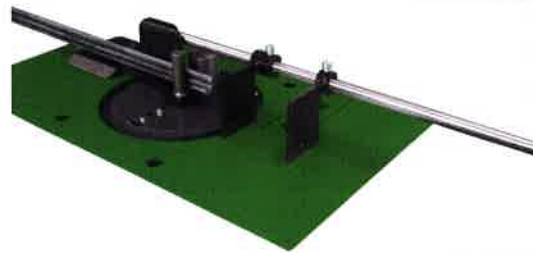

Large radius equipment
Attrezzatura per raggi ampi

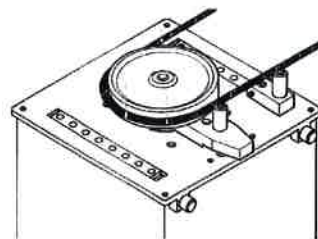
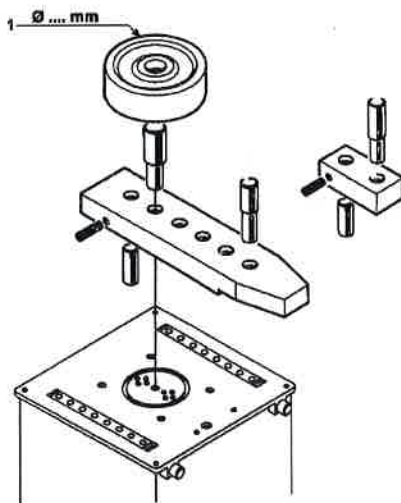
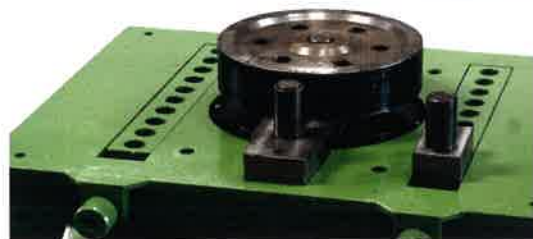

Cutting carriage *Carro da taglio*



Made in
Italy



- Cutting carriage to measure and to cut rebar
- Available with cutting machine 2050 or 2055
 - Capacity to cut rebar 65 Kg/mm² (650 N/mm²) up to diam. 46mm
 - Total length m. 12
 - Total weight Kg. 2700
 - Carriage shift with wheels on rails
 - Winch Kg. 500 to collect rebar from the warehouse

Carro da taglio per misurare e tagliare i tondini:

- Disponibile per le macchine FS2050 o FS2055
- Capacità di taglio tondini 65 Kg/mm² (650 N/mm²) con diametri fino a 46 mm
- Lunghezza totale 12 m.
- Peso totale 2700 Kg
- Argano da kg 500 per prelevare i tondini dal magazzino

